

Centrifugal pumps

Model CA

Sectional Drawing CAC Single Stage

Description

Between bearings pumps which can operate in both vertical inline foot mounted and horizontal installations. Available in both single and two stage impeller. Compact axially split casing design with double suction capabilities with low NPSH requirement.

Single Stage

Capacity: 800-4500 m³/h

Differential pressure: up to 40 mlc.

Two Stage

Capacity: 100-400 m³/h

Differential pressure: up to 120 mlc.

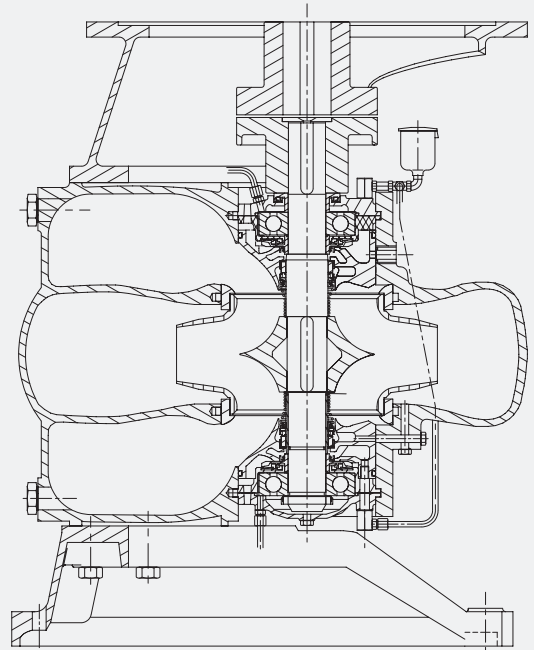

Technical specification

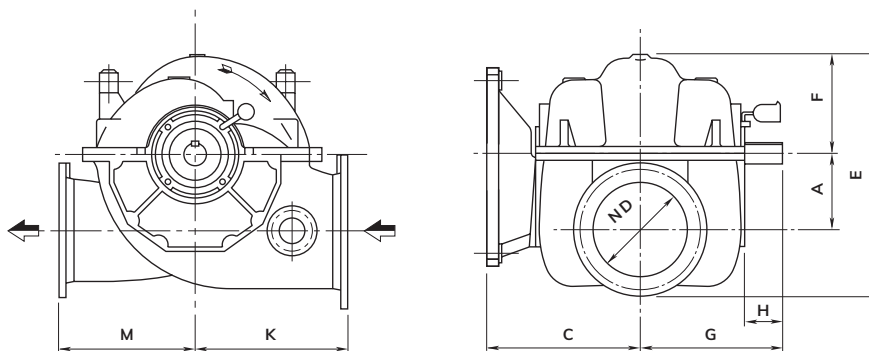

Dimensions (mm)

Pump Size	Inlet ND	Outlet ND	A	C	E	F	G	H	K	M	Weight* (kg)
CAC 200	200	200	200	400	395	256	345	120	400	400	440
CAC 250	250	250	225	400	423	288	345	120	450	450	470
CAC 300	350	300	250	425	792	316	370	120	560	560	620
CAD 350	400	350	280	563	563	355	523	135	560	500	970
CAD 400	450	400	340	600	648	415	523	98	630	560	1270
CAD 450	500	450	380	705	715	480	618	93	750	600	1610
CAD 500	600	500	400	705	790	505	618	93	780	680	1700

*Approximate Weight

Construction code

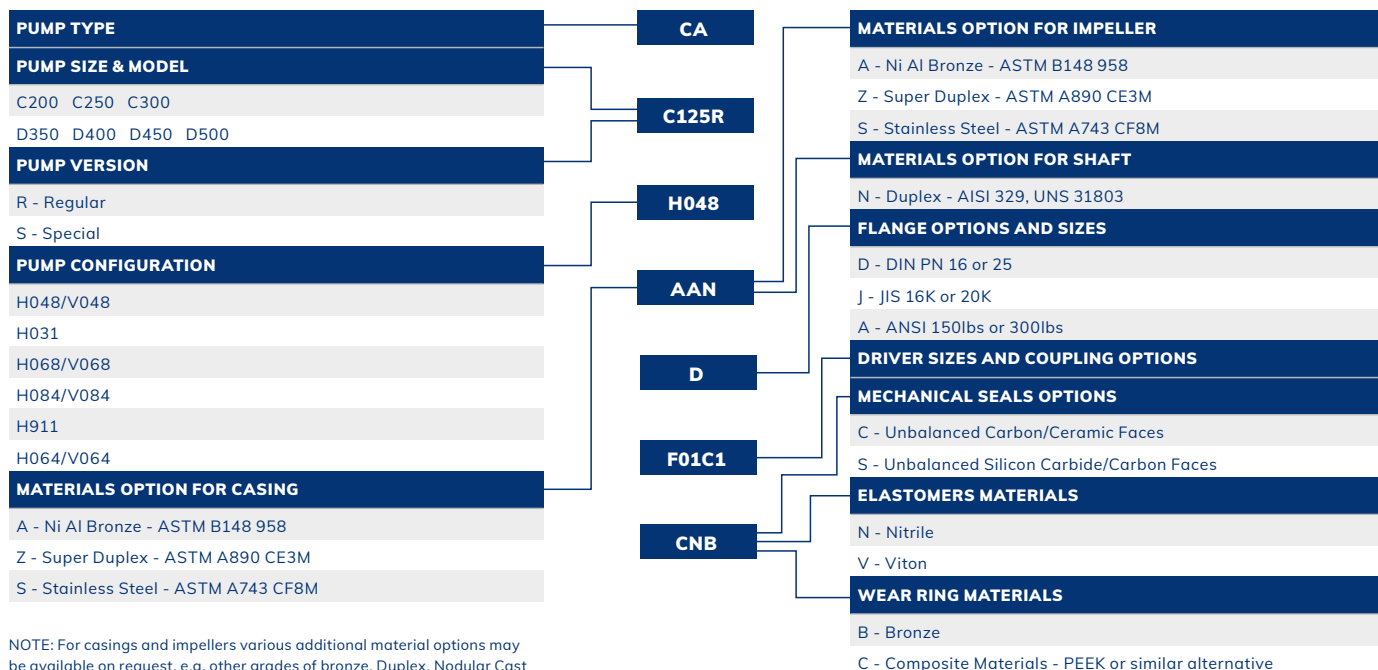

NOTE: For casings and impellers various additional material options may be available on request. e.g. other grades of bronze, Duplex, Nodular Cast Iron etc. For shafts various materials available on request e.g. Monel, Super Duplex - UNS32760 etc. Various mechanical seal options available on request e.g. balanced seal, harden faced seal faces, Hastelloy metals parts etc. For elastomers materials other options available on request e.g. EPDM.

Pump configuration

H = Horizontal / V = Vertical

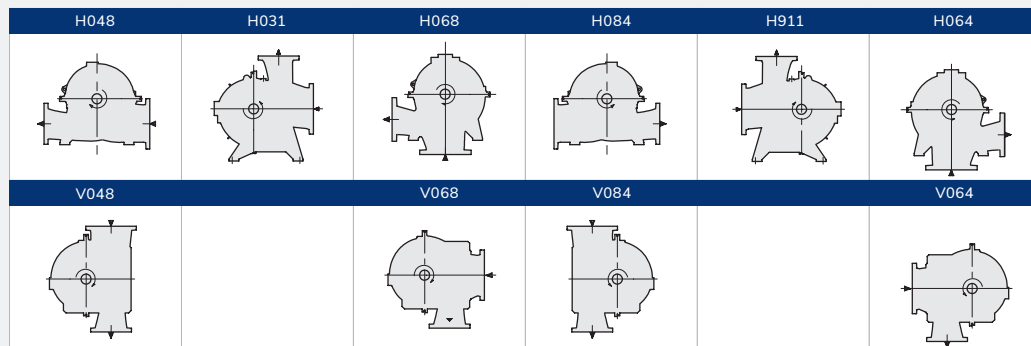

Capacity range

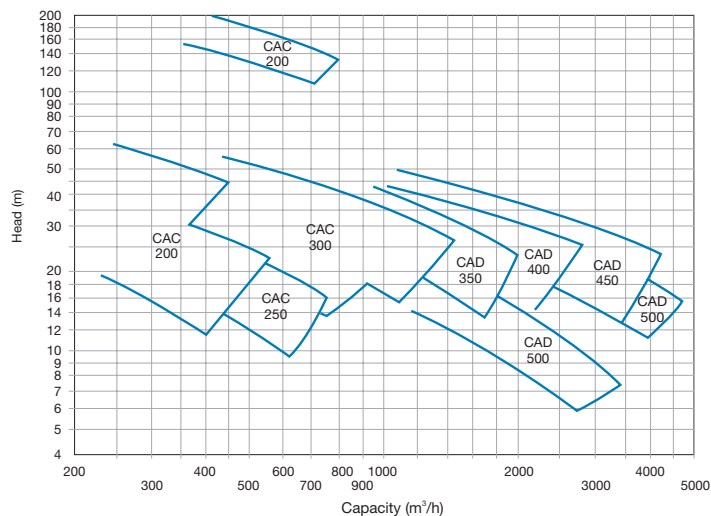

The manufacturers reserve the right to alter the specification and data to incorporate improvements in design. Certified drawings will be issued on request.

© All details copyright Hamworthy Pumps

Website: www.hamworthy-pumps.com

Hamworthy Pumps

Hamworthy Pumps Singapore Pte Ltd

Tel: +65 6261 6066

Email: sgpumpsales@hamworthy-pumps.com

Hamworthy Pumps UK Ltd

Tel: +44 (0) 788 6851102

Email: gbpumps@hamworthy-pumps.com